

<b>JEC</b>		<b>JEC LTD.</b>		
TITLE : FOR JRZL 100 SERIES <b>OUTLINE DRAWING</b>				
DWG.	CHK.	DATE	SCALE	DWG. NO.

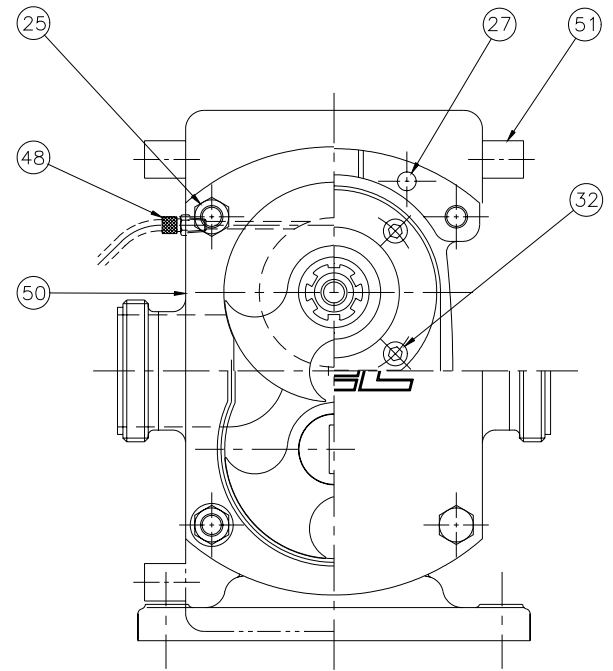
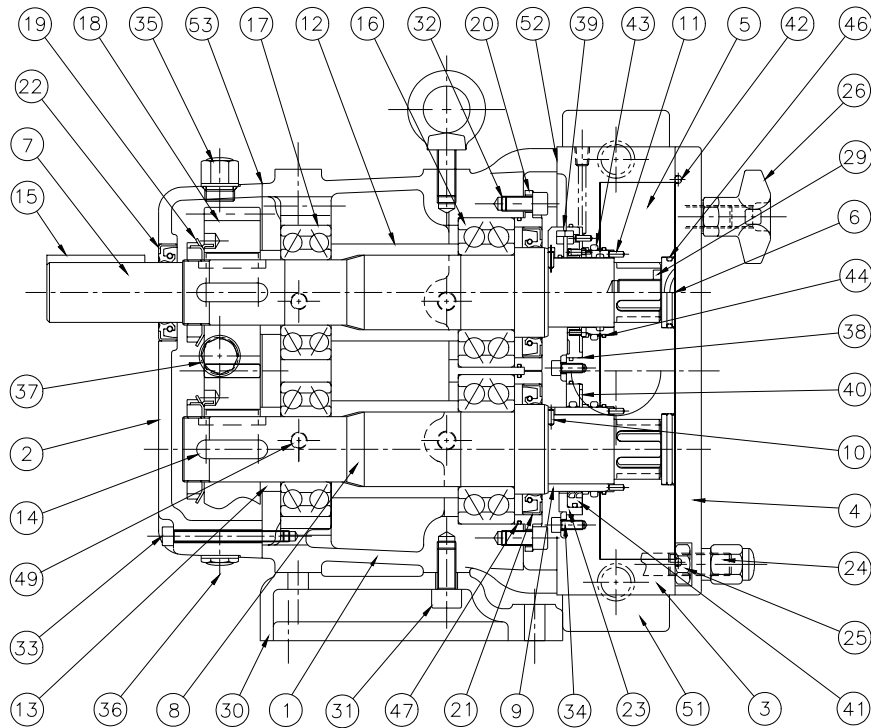

18	HELICAL GEAR	S45C	GRIND	2	36	OIL CAP/ DRAIN	PT 1/2"	1						
17	REAR BEARING		5207	2	35	RELIEF VALVE	PE	PT 1/2"	1	53	GASKET	ASBESTOS	1	
16	FRONT BEARING		5208	2	34	WRENCH BOLT/W	SUS304	M6x10L	4	52	SHIM	SUS304	1	
15	SHAFT KEY	S45C	10x8x50	1	33	WRENCH BOLT	S35C	M8x60L	4	51	HEATING JACKET	SUS304	PT 3/8"	2
14	GEAR KEY	S45C	10x8x27	2	32	WRENCH BOLT	S35C	M8x15L	6	50	NAME PLATE	SUS304		1
13	GEAR SPACER	S25C		2	31	WRENCH BOLT	SUS304	M10x20L	6	49	PLUG	PE	M10	8
12	BEARING SPACER	S25C		2	30	BASE	FCD40		1	48	HOSE NIPPLE		PT 1/8"	2
11	M/SEAL SET PIN	SUS304		6	29	LOCK WASHER	SUS304	M14	2	47	BRG. GLAND O-RING	NBR	AN041	2
10	SEAL SET PIN	SUS304		2	28					46	ROTOR BOLT O-RING	NBR	AN125	2
9	HARDNED SLEEVE	CERAMIC		2	27	DOWEL FOR CASE	SUS304	ø12	2	45				
8	IDLE SHAFT	SUS316		1	26	FRONT COVER NUT	SUS304	M12	4	44	ROTOR O-RING	NBR	AN031	2
7	MAIN SHAFT	SUS316		1	25	LOCK NUT	SUS304	M12	4	43	CASE O-RING	NBR	AN225	2
6	ROTOR BOLT	SUS316		2	24	CASE STUD BOLT	SUS304	M12	4	42	F.COVER O-RING	NBR	AN261	1
5	ROTOR	SUS316		2	23	LIP SEAL GLAND	SUS304		2	41	LIP SEAL	PTFE		2
4	FRONT COVER	SUS316		1	22	REAR OIL SEAL		32x52x8	1	40	O-RING SEAL	NBR		2
3	ROTOR CASE	SUS316		1	21	FRONT OIL SEAL		48x70x12	2	39	DOUBLE MECH. SEAL	TC/TC//TC/TC		2
2	GEAR BOX COVER	FCD40		1	20	OIL SEAL GLAND	SUS304		2	38	SINGLE MECH. SEAL	TC/TC		2
1	GEAR BOX	FCD40		1	19	LOCK NUT/WASHER	S45C		2	37	OIL LEVEL WINDOW		PT 1/2"	2
NO.	DESCRIPTION	MATERIAL	DIM	Q'TY	NO.	DESCRIPTION	MATERIAL	DIM	Q'TY	NO.	DESCRIPTION	MATERIAL	DIM	Q'TY

**JEC JEC LTD.**

TITLE : FOR JRZL 200 SERIES  
ROTARY PUMP

DWG.	CHK.	DATE	SCALE	DWG. NO.
Yungmi	Jmsong	OCT. '99	1/1	DJ-RZL02-0

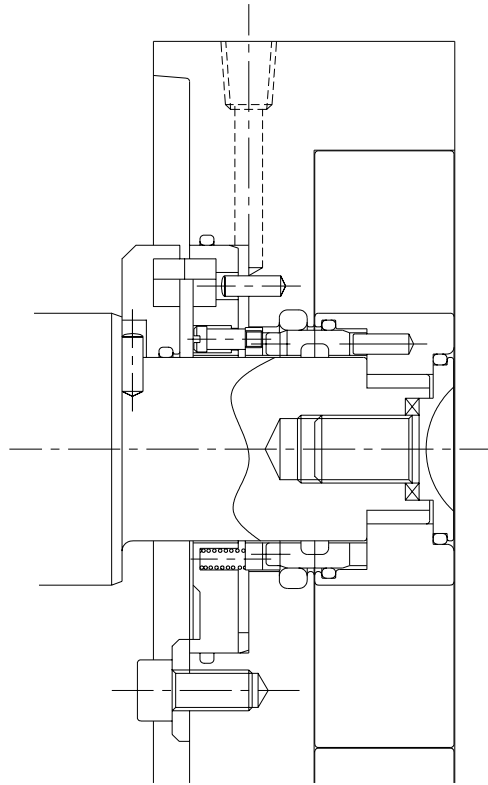

Double Mechanical Seal  
Single Mechanical Seal

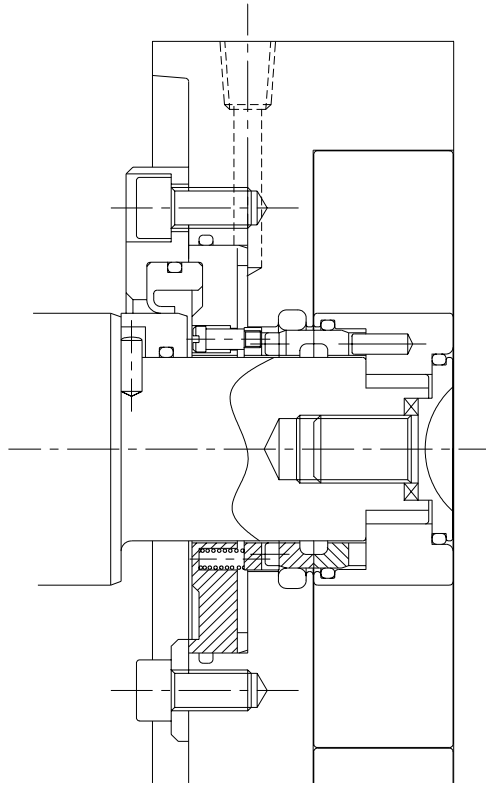

Single Flushed Seal  
Single Mechanical Seal

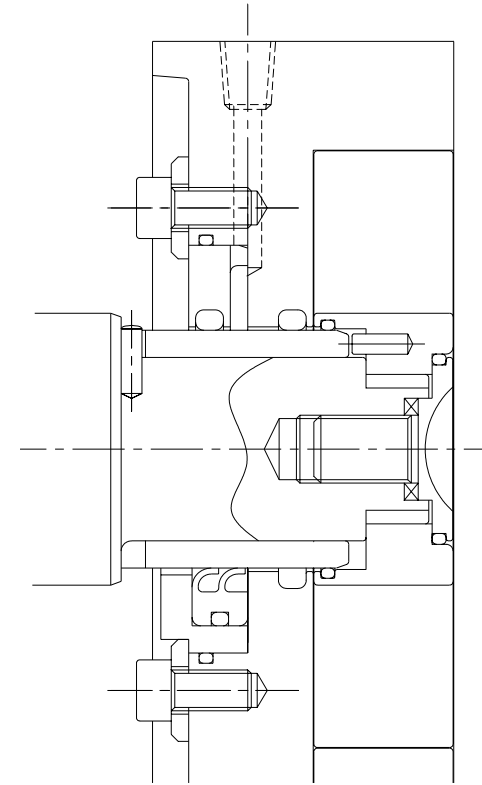

Double O-ring Seal  
Lip-seal

**JEC** JEC LTD.

TITLE : FOR ZL SERIES  
SHAFT SEALING SYSTEM

DWG.	CHK.	DATE	SCALE	DWG. NO.
			1/1	

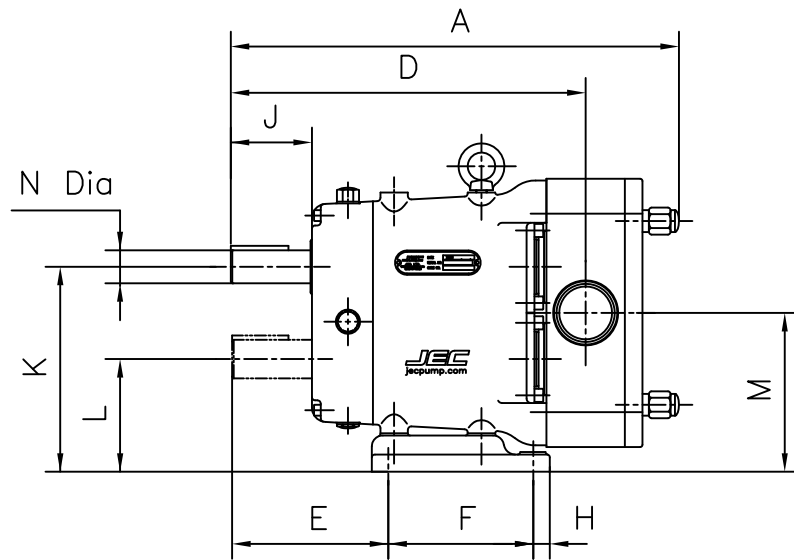

Keyway details  
 X : Length  
 Y : Width

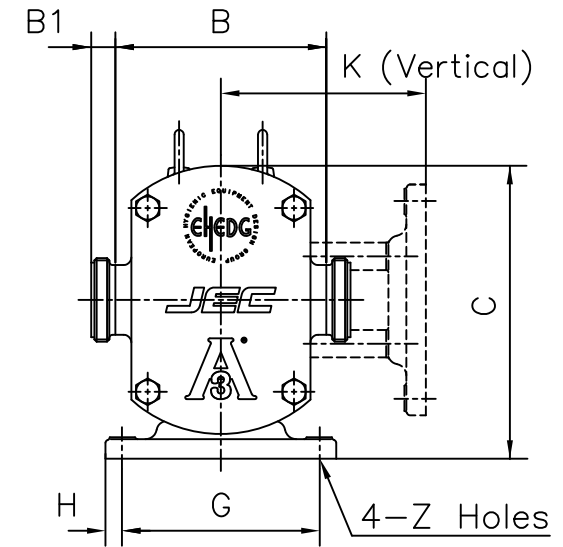

Model no.	Ports	Dimension																
		A	B	C	D	E	F	G	H	I	J	K	L	M	N	X	Y	Z
JRZL105-002-20	1"	255	152	200	218	96	84	134	12	12	50	141	77	109	22	30	8	9
JRZL110-005-20	1"	255	152	200	218	96	84	134	12	12	50	141	77	109	22	30	8	9
JRZL115-012-12	1 1/2"	264	152	200	222	96	84	134	12	12	50	141	77	109	22	30	8	9
JRZL120-021-08	2"	284	152	200	228	96	84	134	12	12	50	141	77	109	22	30	8	9
JRZL220-040-12	2"	386	188	264.5	307	129	132	180	15	15	60	185	101	143	32	50	10	11
JRZL225-062-08	2 1/2"	406	188	264.5	320	129	132	180	15	15	60	185	101	143	32	50	10	11
JRZL330-102-12	3"	533	242	347.5	390	159	160	242	22	22	70	243.5	128.5	186	45	60	14	13
JRZL340-144-08	4"	546	242	347.5	402	159	160	242	22	22	70	243.5	128.5	186	45	60	14	13
JRZL440-227-12	4"	674	324	458	506	198	210	320	30	30	79	324	170	247	55	87	14	15
JRZL450-334-08	5"	709	324	458	522	198	210	320	30	30	79	324	170	247	55	87	14	15

Model no.	Ports	Dimension B1					Weight	Volume
		ISO	BS	DIN	SMS	FLANGE	KG	CBM
JRZL105-002-20	1"	20	26	30	20	30	12	0.01
JRZL110-005-20	1"	20	26	30	20	30	12	0.01
JRZL115-012-12	1 1/2"	20	26	30	20	30	19	0.01
JRZL120-021-08	2"	22	26	30	20	30	23	0.01
JRZL220-040-12	2"	22	26	30	24	30	45	0.03
JRZL225-062-08	2 1/2"	26	26	35	24	35	51	0.03
JRZL330-102-12	3"	28	26	40	24	40	91	0.06
JRZL340-144-08	4"	28	26	54	24	54	103	0.06
JRZL440-227-12	4"	28	26	54	24	54	180	0.15
JRZL450-334-08	5"	28	26	54	35	54	210	0.15

**JEC** **JEC LTD.**

TITLE : FOR JRZL SERIES  
 DIMENSIONAL DRAWING

DWG.	CHK.	DATE	SCALE	DWG. NO.
AN	SONG	Mar. 2012	NONE	DJ-ZL002-1