

BASE MOUNT TYPE

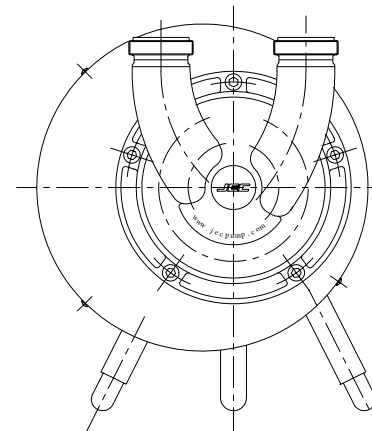
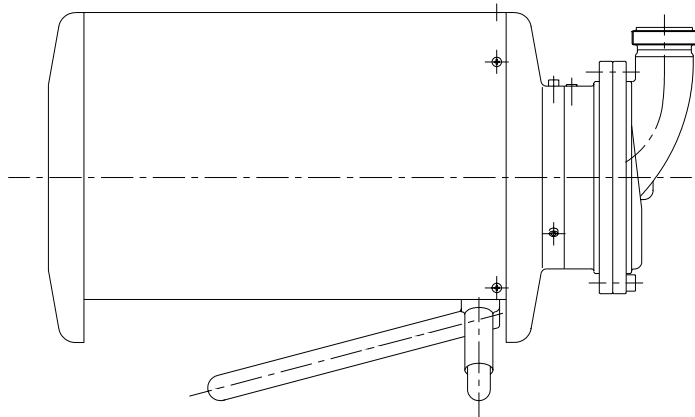

STANDARD TYPE

JEC JEC LTD.

TITLE : FOR JSZ SERIES
OUTLINE DRAWING

DWG.	CHK.	DATE	SCALE	DWG. NO.

CJ - SZ301 - 0

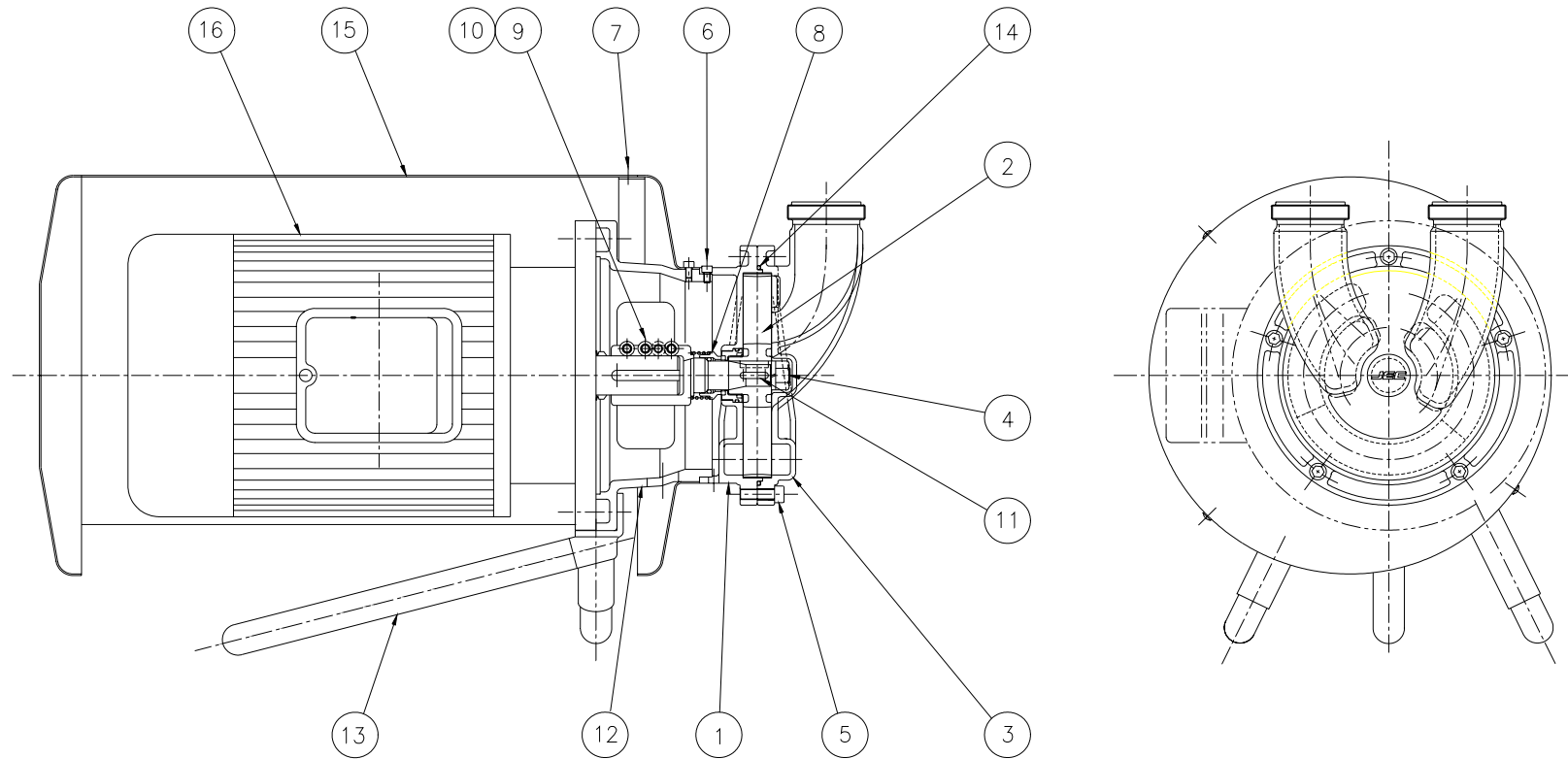

8	MECH. SEAL	TC/CARBON	1 SET	16	MOTOR		1
7	SCREW	SUS 304	3	15	MOTOR COVER	SUS 304	1
6	WRENCH BOLT	SUS 304	3	14	O-RING	NBR	1
5	WRENCH BOLT	SUS 304	5	13	LEG	SUS 304	3
4	NUT & WASHER	SUS 304	1	12	FRAME	SCS13	1
3	FRONT CASING	SCS 14	1	11	KEY	SUS 304	1
2	IMPELLER	SCS 14	1	10	DIRECT COUPLING	SCS 14	1 SET
1	REAR CASING	SCS 14	1	9	SHAFT	SCS 14	1
NO.	DESCRIPTION	MATERIAL	Q'TY	NO.	DESCRIPTION	MATERIAL	Q'TY

JEC JEC LTD.

TITLE : SECTION DRAWING FOR STANDARD VERSION
SELF-PRIMING PUMP

DWG.	CHK.	DATE	SCALE	DWG. NO.
Youngmi	gmsong	OCT. '99	1/1	CJ - SZ301 - 0

STANDARD VERSION

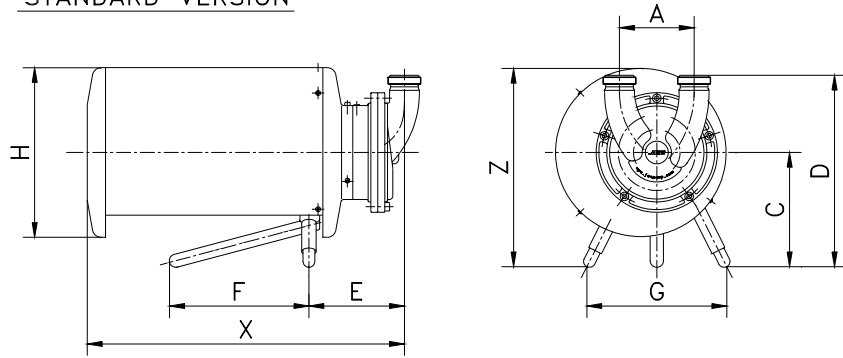

BASE MOUNTING VERSION

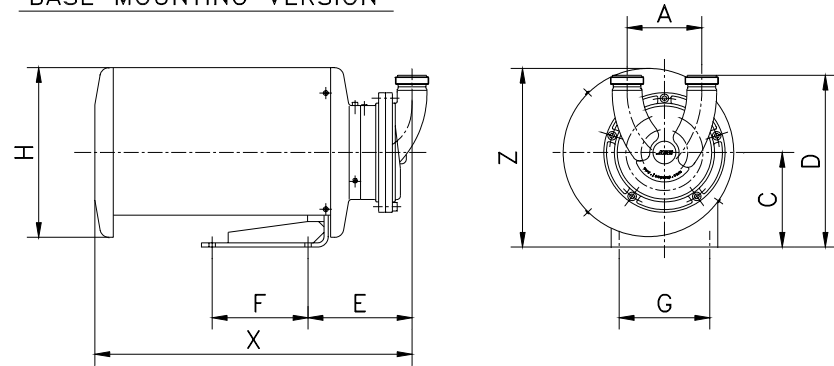

STANDARD VERSION

MODEL NO.	MOTOR		CONNECTION		DIMENSION								WEIGHT VOLUME		
	RPM	KW	SUCT.	DISCH.	A	C	D	E	F	G	H	X	Z	KG	M ³
JSZ624-215/315	1500	1.5/2.2	51	51	140	200	350	185	230	230	270	600	335	41	0.06
JSZ624-318	1800	2.2	51	51	140	200	350	185	230	230	270	600	345	43	0.06
JSZ624-518	1800	3.7	51	51	140	220	390	215	260	260	325	660	380	59	0.08
JSZ927-515	1500	3.7	63	63	150	220	390	215	260	260	325	660	380	63	0.08
JSZ927-715	1500	5.5	63	63	150	260	440	247	315	300	390	745	454	94	0.13
JSZ927-718/1018	1800	5.5/7.5	63	63	150	260	440	247	315	300	390	745	454	99	0.13
JSZ2230-1015	1500	7.5	63	63	170	260	440	247	315	300	390	755	454	105	0.13

BASE MOUNTING VERSION

MODEL NO.	MOTOR		CONNECTION		DIMENSION								WEIGHT VOLUME		
	RPM	KW	SUCT.	DISCH.	A	C	D	E	F	G	H	X	Z	KG	M ³
JSZ624-215/315	1500	1.5/2.2	51	51	140	150	300	195	260	135	270	600	285	41	0.06
JSZ624-318	1800	2.2	51	51	140	150	300	220	315	135	270	600	285	43	0.06
JSZ624-518	1800	3.7	51	51	140	180	330	190	230	170	325	660	342	59	0.08
JSZ927-515	1500	3.7	63	63	150	180	350	190	230	170	325	660	342	63	0.08
JSZ927-715	1500	5.5	63	63	150	220	390	190	230	190	390	745	415	94	0.13
JSZ927-718/1018	1800	5.5/7.5	63	63	150	220	390	220	315	190	390	745	415	99	0.13
JSZ2230-1015	1500	7.5	63	63	170	220	400	190	230	190	390	755	415	105	0.13

JEC JEC LTD.

TITLE : FOR JSZ SERIES/FRAME NO. 90-132
DIMENSIONAL DRAWING

DWG.	CHK.	DATE	SCALE	DWG. NO.
Yongmi	gmSong	NOV.5 '99	NONE	DJ-SZ002-1

BASE MOUNTING VERSION

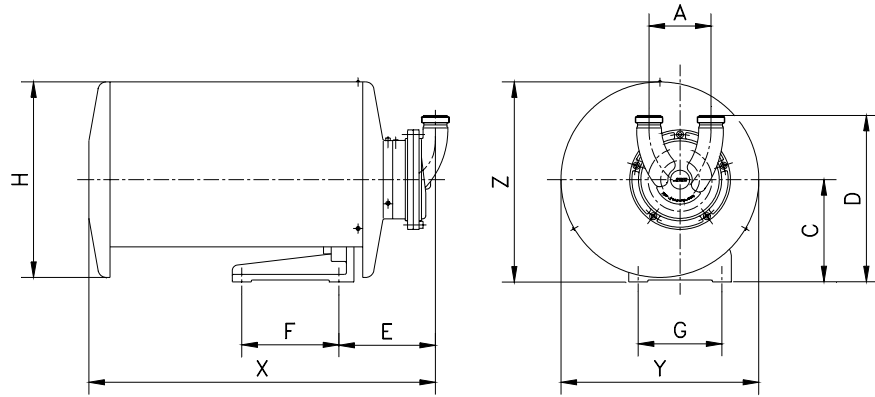

FRAME MOUNTING VERSION

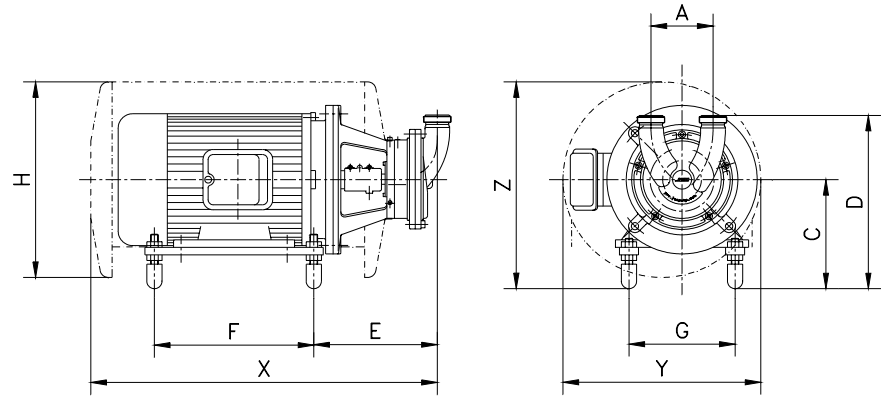

BASE MOUNTING VERSION

MODEL NO.	MOTOR		CONNECTION		DIMENSION								WEIGHT KG	VOLUME M3	
	RPM	KW	SUCT.	DISCH.	A	C	D	E	F	G	H	X			Z
JSZ2230-1515	1500	11	63	63	170	250	430	270	255	220	470	840	485	168	0.2
JSZ2230-1518	1800	11	63	63	170	250	430	270	255	220	470	840	485	168	0.2

FRAME MOUNTING VERSION

MODEL NO.	MOTOR		CONNECTION		DIMENSION								WEIGHT KG	VOLUME M3	
	RPM	KW	SUCT.	DISCH.	A	C	D	E	F	G	H	X			Z
JSZ2230-1515	1500	11	63	63	170	270	450	270	420	254	470	840	485	170	0.2
JSZ2230-1518	1800	11	63	63	170	270	450	270	420	254	470	840	485	170	0.2

JEC JEC LTD.

TITLE : FOR JSZ SERIES/FRAME NO. 160M
DIMENSIONAL DRAWING

DWG.	CHK.	DATE	SCALE	DWG. NO.
Yongmi	gmsong	NOV.5 '99	NONE	DJ-SZ001-2