

JEC CIRCUMFERENTIAL PISTON PUMPS

Take 5S specialty of increasing productivity, profitability and money saving opportunities!!

JRZP SEIRES

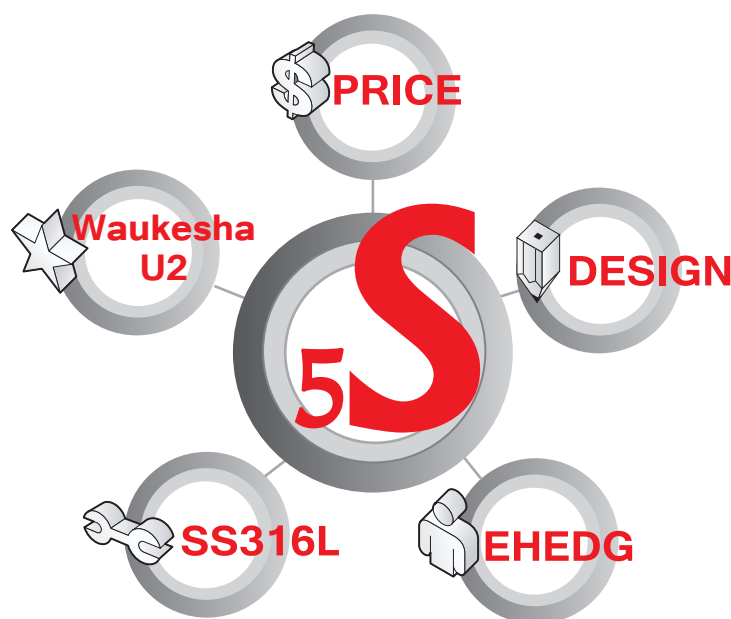

Special construction for EHEDG standards

NEW JEC ZP Series has already been certified by EHEDG in TUV German. It is most reliable CP pumps in the worlds for Clean-in-place(CIP) capability. No-need CIP holes design increases maximizes efficiency even to transfer thin fluids and CIP solutions. Reduced power consumptions because of maximized efficiency with longer sealing paths.

Special price for profitability

ZP Series saves your costs at over 20% rather than competitors as it is realized of cost-down. If SS316L rotor is adapted instead of WM88 rotor, you can enjoy 10% more saving.

Special material of standard stainless steel gear box and SS316L of wetted parts

Standard stainless steel gear box realizes long durability with rust-prevent and paint-free. Moreover, precision investment casting of the gear box shows off a smooth surface without uneven. All of wetted parts are using standard SS316L to meet the stringent GMP standards. These special materials are standards not optional to save customer's money.

Special dimension to easy drop-in to replace Waukesha U2

All of dimensional equivalence to Waukesha U2 enables to replace easily without additional works in the field. To change motor and pump's speed is unnecessary thanks to hydraulically same size even with bigger clearance of stainless steel rotor. WM88 rotors with same clearance as U2 provides 10% bigger capacity than U2.

Smart maintenance due to ideal "FLS" design and external shimming

"FLS"(Front Loading Seal) enables to simply change seals without removing rotor case and cutting pipes. Strong solid Tungsten seal ring is able to last longer seal life. External shimming located between gearbox and casing makes easy fitting of rotor clearance realized less downtime.

JEC CIRCUMFERENTIAL PISTON PUMPS

ZP series are hydraulically and dimensionally same as Waukesha U2 series and so, drop-in to replace U2 series are out of questions. EHEDG certified construction is optimized to meet the GMP requirements and hygienic fields.

JRZP SEIRES EXPLODED VIEW

1. Standard stainless Steel Gear Case for high-resistance to corrosion. Oil bath type lubrication.

5~6. 17-4 PH shaft material twice for stable operation.

7. Precision-grounded helical timing gears.

8. Stainless steel bearing retainer for corrosion.

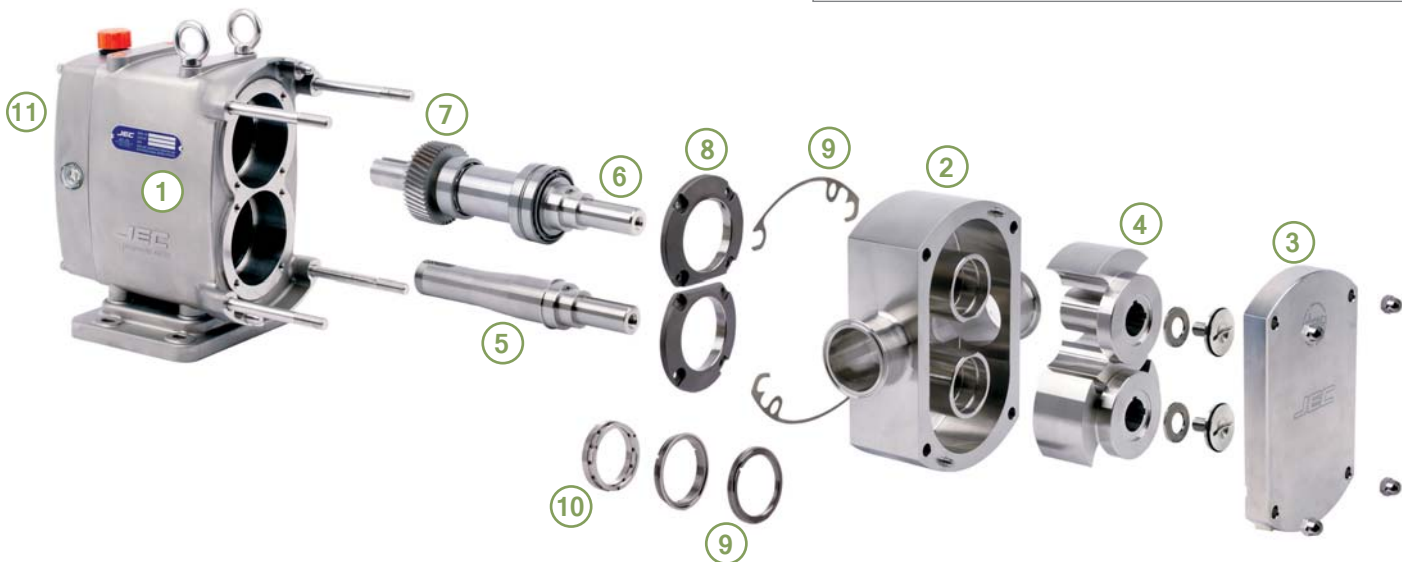

11. Universal positions.

2~3. Standard 316L stainless steel and machined and polished surface for EHEDG and 3A standards.

10. CIP' able seal construction 50% better efficiency in case of thin fluid and CIP solutions. Front loading seal for EHEDG standards reduce down-time of seal replacement.

4. Alloy 88 material rotors with non-galling for better efficiency and suction capability. 2 shaft keys gentle operation at high discharge pressure or external vibration.

9. Mechanical seal, lip seal, o-ring seal allow the pump to be easily adapted to changing conditions of service.

ALWAYS A STEP AHEAD

